

Valvola OVERCENTER semplice effetto in linea  
*In line, single effect COUNTERBALANCE valve*  
 mod. OVC-SE-L

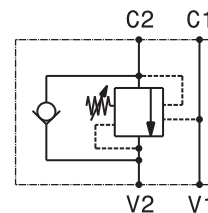
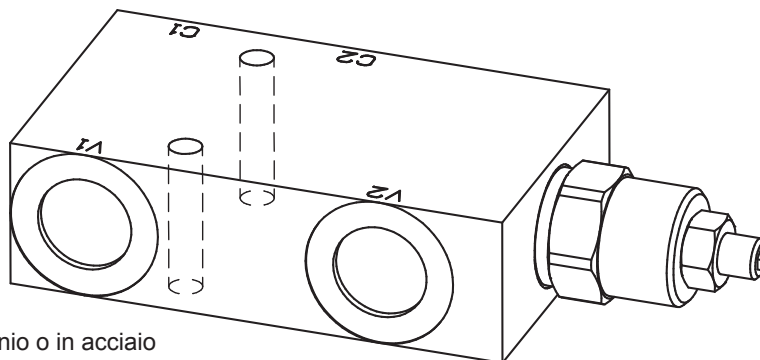

Versione corpo in alluminio o in acciaio  
*Aluminium or steel body version*

Pressione massima <i>Max pressure</i>	350 bar 5000 psi
Rapporto di pilotaggio standard <i>Standard pilot ratio</i>	4,25:1 (G3/8" - G1/2"), 4:1 (G3/4" - G1")
Rapporto di pilotaggio a richiesta <i>Pilot ratio upon request</i>	3:1 8:1 10:1
Dati e tarature ottenuti usando olio con viscosità 30 cSt a 50°C <i>Performances and calibrations are carried out by using hydraulic oil with 30 cSt viscosity at 50°C</i>	
Viscosità consigliate <i>Recommended viscosity</i>	10 ÷ 420 cSt
Temperature di lavoro <i>Working temperature</i>	-20 ÷ +90 °C
Filtrazione assoluta <i>Absolute filtration</i>	25 µ

Modello <i>Type</i>	V1, V2 C1, C2	Portata max <i>Max. flow</i>
OVC-SE-L-38	3/8" GAS	40 l/min 10.5 gpm
OVC-SE-L-12	1/2" GAS	70 l/min 18 gpm
OVC-SE-L-34	3/4" GAS	110 l/min 26 gpm
OVC-SE-L-10	1" GAS	120 l/min 32 gpm

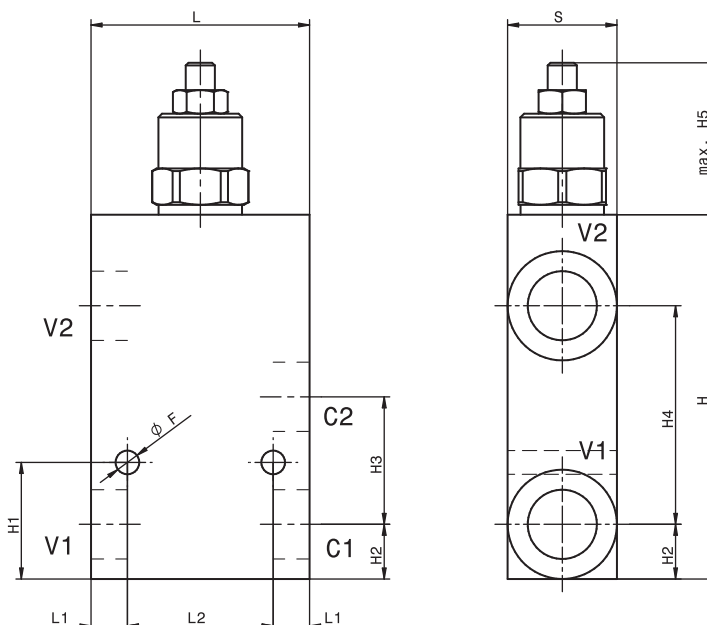

Modello <i>Type</i>	L	H	S	L1	L2	H1	H2	H3	H4	H5	F
OVC-SE-L-38	60	100	30	10	40	32	15	35	60	42	6.5
OVC-SE-L-12	60	100	30	10	40	32	15	35	60	42	6.5
OVC-SE-L-34	70	125	40	10	50	42.5	20	45	80	48	8.5
OVC-SE-L-10	70	140	50	10	50	51	25	52	90	48	8.5

**Taratura Setting**  
 La valvola deve essere tarata almeno 1.3 volte la massima pressione indotta dal carico  
*The valve must be set at least 1.3 times maximum load induced pressure*

Codice <i>Code</i>	Taratura standard <i>Standard setting</i> (Q=5 l/min)	Campo di taratura <i>Adj. Pressure range</i>	Colore molla <i>Spring color</i>
01	100 bar 1450 psi	20+200 bar 290+2900 psi	Bianco White
02	280 bar 4000 psi	50+350 bar 725+5000 psi	Nero Black

Regolazioni - Adjustments

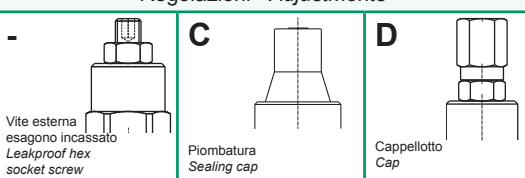

Sigla di ordinazione / Ordering code

OVC-SE-L-38 - 02 - - -

Modello <i>Type</i>	Codice taratura <i>Setting code</i> 01, 02	Codice regolazione <i>Adjustment code</i> -, C, D	- Alluminio / Aluminium A Acciaio / Steel
------------------------	--	---	--

For flow diagram see  
 PRESSURE DROP OVERCENTER VALVES (8) +  
 PRESSURE DROP OVERCENTER VALVES (9)

I dati non sono impegnativi, CBF si riserva di apportare modifiche senza preavviso.  
*The specifications are not binding, CBF reserves the right to introduce modifications without notice.*